

Example of installation of an insulating flange connection type HP2

Without cable lugs, example 8-hole flange:

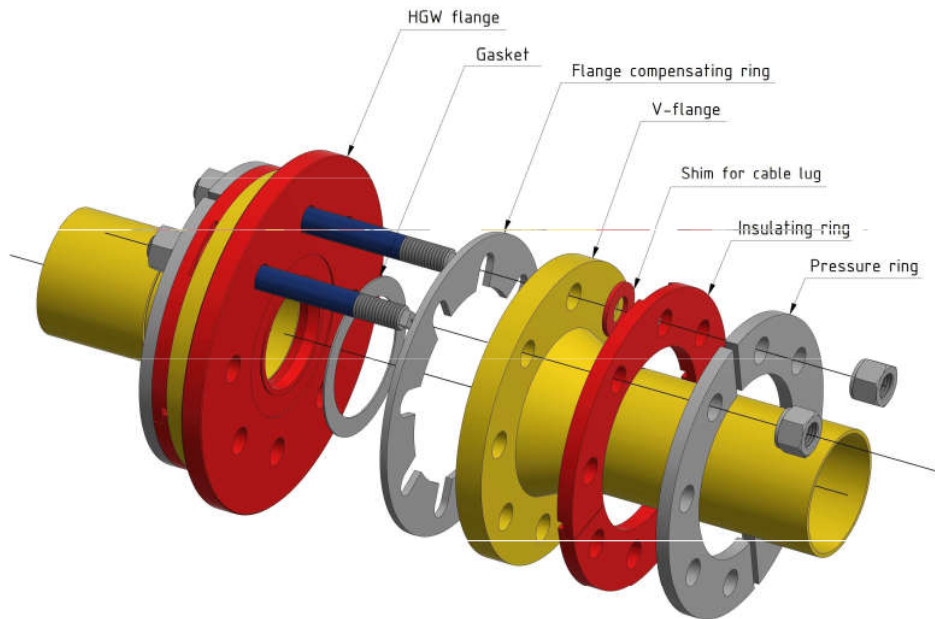

With cable lugs, example 8-hole flange:

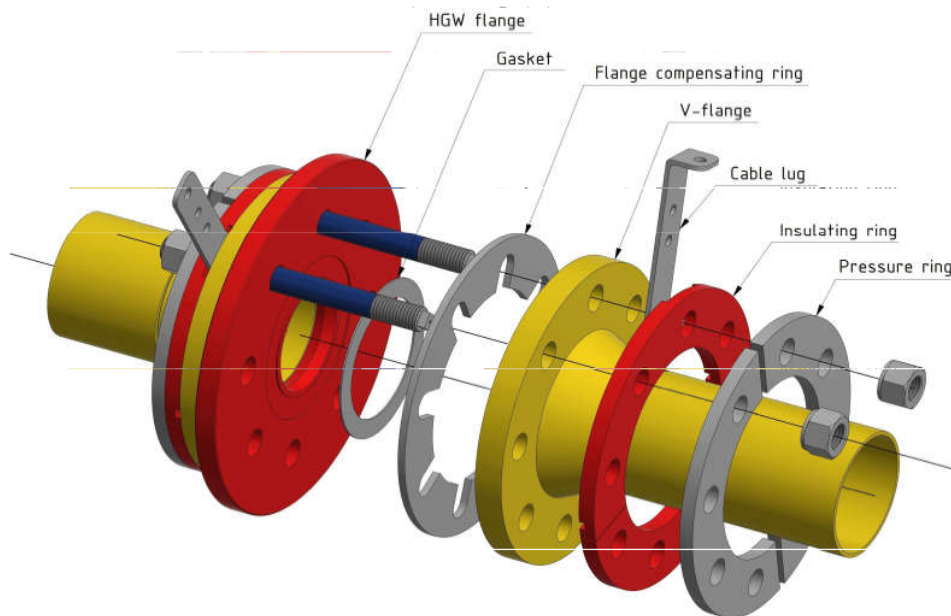

The torque to be applied is indicated in the documentation drawing of the insulating flanges.

Stud-bolt with self-lubricating coating.

Coefficient of friction of 0.12 is met for up to 5 assembly processes.

PLEASE OBSERVE: No lubrication required!

ISOflanges GmbH
Viehtrift 1
29308 Winsen

Tel: 05143 923 49 0
Mail: info@isoflanges.de
www.isoflanges.de