

ISOflanges GmbH – Winsen (Aller)

Analysis of hazards and risks / Instructions for operation and use

Insulating Flange Connection Type HQ2

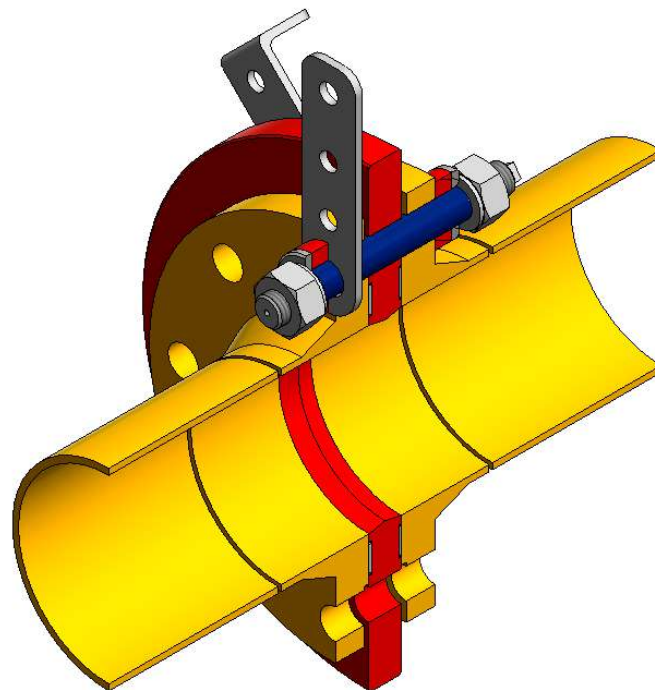

Assembly example with cable lug

Figure 1

Table of contents:

1. Analysis of hazards and risks

- 1.1. General information
- 1.2. Hazard analysis

2. Instructions for operation and use

- 2.1. Introduction
- 2.2. Data on the nameplate
- 2.3. Design and installation/assembly
 - 2.3.1. Preparation of the installation on site
 - 2.3.2. Assembly instructions
 - 2.3.3. Assembly of flange connections
 - 2.3.4. Installation cable lugs and explosion spark gaps
 - 2.3.5. Installing ISO-U-washers/steel-U-washers
- 2.4. Commissioning
- 2.5. Use and operation
 - 2.5.1. Operating conditions for the insulating flange connections
 - 2.5.2. Painting of the insulated flange connections
 - 2.5.3. Bolt insulation
 - 2.5.4. Bolt coating/corrosion protection
 - 2.5.5. Torque calculation
- 2.6. Maintenance and inspection
- 2.7. Documentation
- 2.8. Dismantling / disposal

1. Analysis of hazards and risks

1.1. General information

The hazards and risks analysed in this document must be strictly observed and the instructions must be followed prior to use and/or installation.

1.2. Hazard analysis

If the product is used properly, no hazard is to be assumed

Hazard analysis HQ2 insulating flange connection

Hazard	Possibility	Explanation	Measure
1. Exceeding the max. permitted internal or external pressure	Yes	Max. operating pressure is indicated on the name plate; information in the operating instructions	The operator is responsible not to exceed the max. permitted pressure
2. Exceeding the max. or min. permitted temperatures or the temperature gradient	Yes	Max./min. operating temperature is indicated on the name plate; information in the operating instructions	The operator is responsible not to exceed the max. permitted temperature ranges
3. Exceeding the design features relevant for the lifecycle of the device with respect to creep effects, fatigue and corrosion	No	HQ2 insulating flanges are not permanently tight and mechanically maintenance-free	The operator is responsible for monitoring and checking the insulating flange connection for leaks
4. Hazards due to the static pressure and device content under operating and test conditions	No	HQ2 insulating flanges are not permanently tight and not mechanically maintenance-free	The operator is responsible for monitoring and checking the insulating flange connection for leaks
5. Exceeding the static load and the traffic, wind, snow or earthquake loads	n/a	/	/
6. Exceeding of reactive forces and moments resulting from supports, fittings and pipelines etc.	n/a	/	/
7. Decomposition of unstable fluids	n/a	/	/
8. Aspects of instability	n/a	/	/
9. Faulty handling of closures and openings	No	Note in the operating instructions: To be installed by qualified personnel only	/
10. Dangerous unloading of pressure relief valves	n/a	/	/
11. Faulty handling of devices to avoid physical access in the event of overpressure or vacuum	n/a	/	/
12. Surface temperature in consideration of the intended use	No	Max./min. operating temperature is indicated on the name plate; information in the operating instructions	/
13. Faulty handling of unstable fluids leading to their decomposition	n/a	/	/
14. Faulty drainage and ventilation with the following possible consequences:			
14.1. Water hammer, implosion, corrosion and chemical reactions	n/a	/	/
14.2. Obstruction of safe cleaning, inspection and maintenance	n/a	/	/

Hazard analysis HQ2 insulating flange connection

Hazard	Possibility	Explanation	Measure
15. Excessive wear	Yes	HQ2 insulating flanges are not permanently tight and mechanically maintenance-free	The operator is responsible for monitoring and checking the insulating flange connection for leaks
16. Faulty assembly of components	Yes	Note in the operating instructions: To be installed by qualified personnel only	The operator must use qualified personnel and observe the operating instructions
17. Faulty filling and drainage			
17.1. Overfilling or exceeding the permitted pressure	Yes	Max. operating pressure is indicated on the name plate; information in the operating instructions	The operator is responsible not to exceed the max. permitted pressure
17.2. Instability of the pressure device	Yes	HQ2 insulating flanges are not permanently tight and mechanically maintenance-free	The operator is responsible for monitoring and checking the insulating flange connection for leaks
17.3. Uncontrolled escape of the fluid under pressure	Yes	HQ2 insulating flanges are not permanently tight and mechanically maintenance-free	The operator is responsible for monitoring and checking the insulating flange connection for leaks
17.4. Unsafe connection and separation	Yes	Note in the operating instructions: To be removed by qualified personnel only	The operator must use qualified personnel and observe the operating instructions
18. Inappropriate failure of equipment parts with safety function, of devices for pressure limitation or temperature monitoring, e.g. with respect to:			
18.1. Reliability for the intended use	Yes	HQ2 insulating flanges are not permanently tight and mechanically maintenance-free	The operator is responsible for monitoring and checking the insulating flange connection for leaks
18.2. Maintenance and test requirements	Yes	HQ2 insulating flanges are not permanently tight and mechanically maintenance-free	The operator is responsible for monitoring and checking the insulating flange connection for leaks
18.3. Independence of other functions	Yes	HQ2 insulating flanges are not permanently tight and mechanically maintenance-free	The operator is responsible for monitoring and checking the insulating flange connection for leaks
19. Inappropriate failure of measures against fire from outside	Yes	HQ2 insulating flanges are not resistant against fire from outside	The operator must specify measures in the fire protection concept / safety concept

2. Instructions for operation and use

2.1. Introduction

The insulating flange connection type HQ2 is used for the safe electrical separation of steel pipes in connection with a CCP system (cathodic corrosion protection system) and in “black and white connections” to protect bimetallic corrosion. The insulating flange connection is suitable for gaseous media (also for gases according to G 260) and liquid media and is designed in such a way that it can withstand the usual operating loads without any problems (provided it is installed correctly) and fully complies with its functional capability. It is not necessary to disassemble the insulating flange connection during the pressure test (test pressure max. 1.5xDP) of the pipeline, the insulating flange connection can remain in the pipeline. In contrast to the HP2 system from ISOflanges, the HQ2 system is not state of the art technology, is not mechanically maintenance-free, and is not permanently technically sealed in accordance with TRBS 2141-3 and TRBS 2152-2. Regular leak testing, for instance in accordance with G495, is required.

2.2. Data on the nameplate

The identification of the insulating flange connection consists of a weatherproof, permanent type plate, which is glued to the circumference of the hard fabric flange. As additional protection, the nameplate is provided with a laminate which is UV-resistant and protects against various external influences, as well as liquids and moisture. In the assembly of the insulation flange connection it is important that the insulating flange is positioned for the nameplate to be well visible and easily readable. The insulating flange connection is marked as follows (example):

Manufacturer; nominal size; design pressure; operating pressure; temperature; CE-conform; year of manufacture; serial No.:



DN50 PN10-40 PS 40bar TS -20°C/+60°C C € 0045 2021 C0123.456

Analysis of hazards and risks

The nameplate must be handled with care and must be protected against damage and external mechanical forces that reduce the legibility of the nameplate.

If this is not observed, proper identification or allocation to the Acceptance test certificate is no longer possible and there is a risk of loss of the approval.

2.3. Design and installation/assembly

2.3.1. Preparation of the installation on site

- Comparison of the planning documents with the on-site situation
- Inspection of the parts intended for installation
- Selection of suitable tools

Analysis of hazards and risks

In case of non-observance, as well as when mounting dirty or damaged components, the electrically insulating function of the insulating flange connection is not guaranteed. There is danger to people and the environment.

2.3.2. Assembly instructions

- A flange connection can only fulfil its function safely if the elements of the flange connection, correctly dimensioned for the intended use, are also correctly installed.
- Seal must be visually inspected before use and must not be reused after installation.
- Sealing surfaces must be clean, free of residues, undamaged and free of grease. This also applies to the groove of the insulating flange.
- Flanges must be able to be joined flush and smoothly without the application of force.
- Assembly must generally be carried out using suitable torque-monitoring tools. These tightening torques only apply on condition that the threads of the stud bolts and the contact surfaces of the nuts have been treated with suitable lubricants for this purpose (lubrication of the force-transmitting components). In the case of the bolts used, this is achieved by means of the self-lubricating zinc flake coating. No additional lubricant is required.
- Overloaded or overextended bolts must be replaced.
- Spare parts may only be obtained from the manufacturer.

2.3.3. Assembly of flange connections

- The screw bolts are provided with a self-lubricating coating - no lubrication or greasing is required.
- If an additional lubricant has been applied by the operator, then the operator must ensure that the friction value of $\mu_{ges} = 0.12$ is maintained. Better or worse friction values can lead to failure of the flange connection and are therefore the responsibility of the operator.
- The insulating properties of the materials used may be impaired by additionally applied lubricant, resulting in insufficient insulation values. No grease or screw pastes may be applied to the seal or the sealing surface.
- The components must not be mounted in a dirty condition. The insulating flange connections and their individual components must be dry and clean before assembly.
- Bolted connections on flanges must not be tightened under operating pressure. Leaking flange connections must be reassembled, using new gaskets.
- Seals, bolts and nuts must be treated accordingly as safety-relevant components.
- The insulated studs must be installed in such a way that the stud insulation is located in the center of the flange connection and the stud has an equally large projection on both sides of the welding neck flanges. The stud insulation protrudes from the welding neck flange, so that the insulation ring still to be fitted covers the protruding stud insulation.
- To ensure that the flanges are aligned, the self-lubricating bolts must be used in the lower area of vertically aligned flanges.
- In order to ensure a professional and stress-free assembly of the flange connections, the correct sequence must be planned/defined before starting the work. The stress-free installation of the insulating flange connection is a prerequisite for proper functioning.

- Tightening the bolts is done in at least 5 steps:
 - Step 1: approx. 10 - 20% of the assembly tightening torque (crosswise)
 - Step 2: Check that the flange connection is flush and smooth so that the sealing surfaces are evenly seated on the gasket
 - Step 3: approx. 50 - 70% of the assembly tightening torque (crosswise)
 - Step 4: 100% of the assembly tightening torque (crosswise)
 - Step 5: 100% of the assembly tightening torque (all around)
- Alternative approved methods for tightening the bolts are also permitted in individual cases.

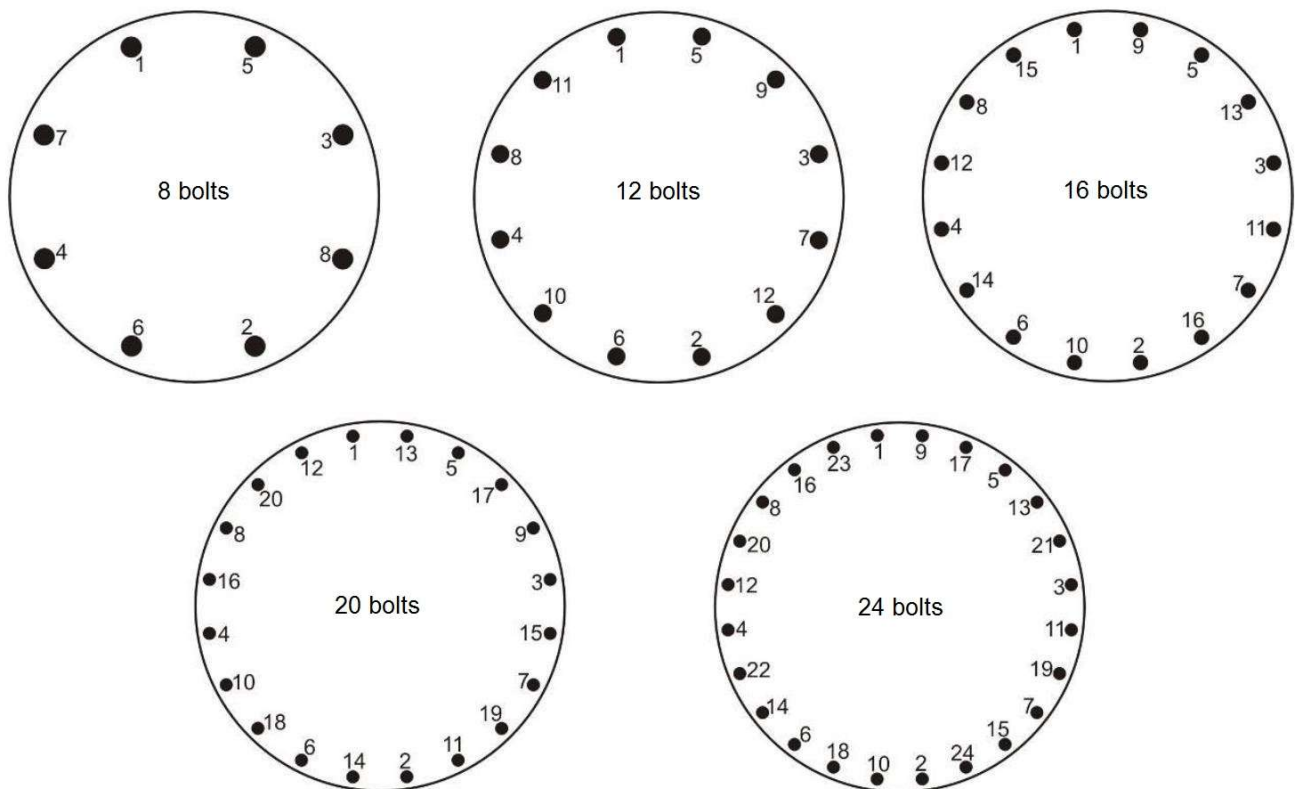

Figure 2

2.3.4. Installing cable lugs and explosion spark gaps

The contact surfaces of the cable lugs must be blank metal and must be coated in terminal grease. There may be no paint residue, no corrosion or other coatings. The screw bolt intended for installing the cable lugs is pre-assembled with the cable lug. This screw bolt has thinner insulating washers (10mm), to ensure the bolt length is identical to the other screw bolts. The warranty applies only to cable lugs from the manufacturer; the use of other cable lugs is not permitted.

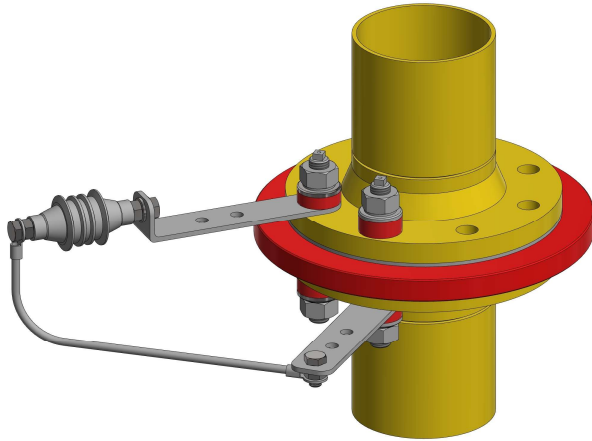

Figure 3

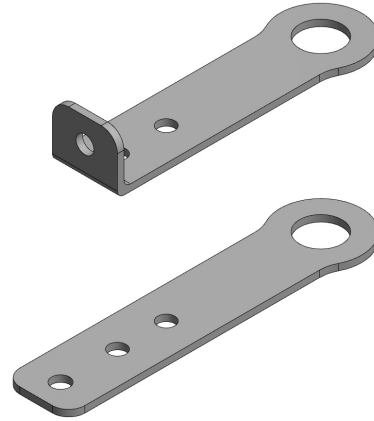

Figure 4

When installing explosion isolating spark gaps, the associated installation instructions must be observed and complied with. The Ex isolating spark gaps are mounted on the supplied cable lugs as shown in Figure 3.

2.3.5 Installing ISO-U-washers/steel-U-washers

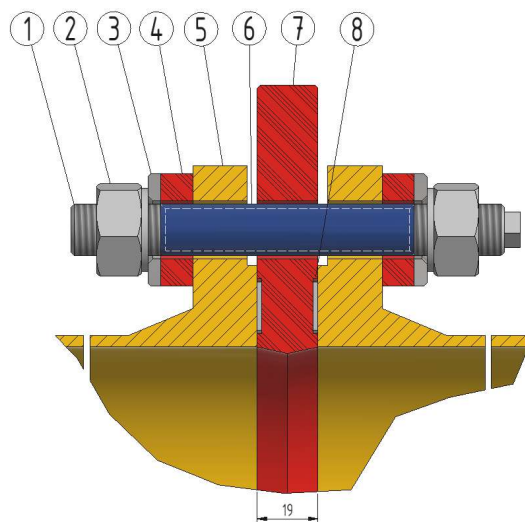

Figure 5

- | | |
|---------------------------------------------|--------------------------|
| 1. Screw bolts similar to DIN2510 | 5. V-flange (optional) |
| 2. Nuts in accordance with DIN2510 | 6. Screw bolt insulation |
| 3. Rotated steel-U-washers | 7. Insulating flange |
| 4. ISO-U-washers 14 mm thick | 8. Corrugated gasket |
| ISO-U-washers 10 mm thick (cable lugs opt.) | |

2.4. Commissioning

A risk assessment must be available before starting work. This is not included in the scope of delivery and must be created by the customer. According to BetrSichV (Industrial safety regulations), the requirements to be met for occupational health and safety as well as for plant safety must be specified. Essential organisational requirements include:

- Flanged joints must always be designed and calculated according to the intended use.
- The assembly of the flange connections may only be carried out by qualified assembly personnel in accordance with BetrSichV §2 and §10.
- The tightening procedure and the tightening torque or pretensioning force of the bolts must be specified for the assembly personnel (see documentation drawing).
- The instructions for use and operation must be made available to the installation personnel.
- Only approved and suitable tools may be used.
- No changes whatsoever may be made to the insulating flange connection as a whole or to individual components. Only materials supplied by the manufacturer may be installed.

Analysis of hazards and risks

The safety instructions must be observed.

If the safety instructions are not observed, the safety and health of the personnel and also the functionality of the component is at risk.

2.5. Use and operation

2.5.1. Operating conditions for the insulating flange connections

- This document is valid for the assembly of ISOflanges GmbH insulating flange connections, type HQ2 at ambient temperatures from -20 °C to +60 °C and in pressureless condition.
- The instructions are to be used when mounting and dismantling metallic flanged joints on pipelines and pressure equipment. A flange connection is a detachable connection between apparatus, pressure equipment, machine or pipeline elements.
- Pipelines to be connected may only be installed and operated free of forces and torques.
- In order to ensure the correct operation and tightness of the insulating flange connection, it is imperative that the flanges used comply with the applicable standards for which the insulating flange connection is designed.
- The maximum permissible operating pressure is stated in the attached inspection certificate and must not be exceeded.
- Before installation, the components must be checked for perfect condition, only undamaged components may be installed.
- The components of the insulating flange connection as well as the tools to be used must be stored properly and/or be suitable and calibrated.
- The compatibility between the medium and the insulating flange connection or the sealing material is the responsibility of the operator.

Analysis of hazards and risks

If the sealing face is lower than the balancing ring, the latter must be adjusted. Assembly without adjustment is not permitted because the tightness cannot be guaranteed.

Non-compliance with these operating instructions may endanger people and the environment. No liability is assumed for damage of any kind resulting from non-compliance with this document.

2.5.2. Painting of the insulated flange connections

When delivered, the insulating flange is painted in a signal colour (orange) so that it can be easily recognised as an insulation separation point and to protect the material from weathering.

The paint consists of a 2K polyurethane acrylic paint and has the following properties:

- high UV and weather resistance
- very good water resistance
- resistant to solvents
- continuous temperature load: 150 °C

The insulating flange connection must not be painted over in any form. This would mean the loss of functionality and warranty.

2.5.3. Bolt insulation

Care must be taken that the insulation is not damaged. There must be no spalling, cracks or other damage. The screw bolts must be carefully protected against damage. If there is any damage, the bolts must not be used any more. Spare parts may only be obtained from the manufacturer.

The flanges must be joined flush and smoothly. Flange blades with parallel alignment and no centre offset are required for correct installation. Care must be taken to ensure that the bolts can be passed through the bolt holes in the flanges without damaging the insulation by the edges of the holes. No torsional forces must be applied to the screw bolts. The screw bolts must not be turned in the screw holes.

Analysis of hazards and risks

If this is not observed, damage to the electrically insulating bolt insulation is possible and thus the function of the insulating flange connection cannot be guaranteed.

2.5.4. Bolt coating/corrosion protection

The self-lubricating coating of bolts and nuts consists of a zinc flake coating as priming coat and a solvent-based cover coat. Defined friction coefficient $\mu_{ges} = 0,12$.

If an additional lubricant has been applied by the operator, then the operator must ensure that the friction value of $\mu_{ges} = 0.12$ is maintained. Better or worse friction values can lead to failure of the flange connection and are therefore the responsibility of the operator.

The insulating properties of the materials used may be impaired by additionally applied lubricant, resulting in insufficient insulation values.

To keep the coating properties, the surface must never be brought into contact with any cleaning agents, dilutants or other agents that could potentially harm a solvent-based surface.

The procedure of zinc flake coating is described in the norms DIN EN ISO 10683 and DIN EN ISO 13858.

Corrosion resistance DIN EN ISO 9227 / ASTM B117

guarantees cathodic corrosion resistance as required in DIN EN ISO 10683 and passes the salt spray test DIN EN ISO 9227 and required in DIN EN ISO 10683.

Analysis of hazards and risks

It has to be ensured that the coating is not brought into contact with cleaning agents, dilutants or other agents (that could potentially harm a solvent-based surface). If this is not observed, damage to the coating is possible, leading to corrosion.

2.5.5. Torque calculation

The flange connection has to meet certain defined tightness requirements depending on the application. A mathematical tightness and strength verification for the system is carried out according to DIN EN 1591-1. The torque to be applied is supplied by ISOflanges and is noted on the documentation drawing.

The insulating flange connection may only be tightened to this torque. For mounting and applying the torque, the mounting instructions listed must be observed.

The calculation of the torque is done at a friction coefficient of 0.12 and refers to the components supplied by ISOflanges.

The flanges according to DIN EN 1092-1 or ASME B16.5, which are not included in the scope of delivery, are included in the calculation with standard materials. These materials are: P235GH, P250GH, P355QH1, C22.8, C21. Materials providing equal physical properties are taken into account as well and can be tightened with the same torque. If other flanges with deviating physical properties are used, an adapted mathematical verification is required.

2.6. Maintenance and inspections

Type HQ2 insulating flange connections from ISOflanges are not mechanically maintenance-free, and must be monitored and checked for leaks at regular intervals according to the risk analysis. For systems with a MOP above 5 bar, the technical seal is monitored via recurring inspections in accordance with DVGW worksheet G495 or DVGW data sheet G265-2.

2.7. Documentation

The associated documentation is issued by ISOflanges and is part of the insulating flange. The insulating flange must not be operated without documentation.

- EU Declaration of Conformity ISOflanges GmbH or Certificate of conformity by TÜV Nord
- APZ 3.1 according to DIN EN 1594 or test report of the acceptance from TÜV Nord
- Documentation drawing
- Operating Instructions / Hazard analysis / Installation instructions

The certificates of the individual components are documented and archived by the manufacturer, but are not part of the delivery. The conformity of the complete component according to PED is certified by the manufacturer according to the declaration of conformity.

2.8. Dismantling/disposal

As a basic principle, only unpressurised and drained pipes and plant components may be opened. For this purpose, the system must be taken out of operation properly before disassembly.

When the flanges are cleaned, the insulating flange connection can be fitted with a new gasket. Seals are generally to be used only once. Bolts and nuts intended for reinstallation must be checked for suitability and replaced if necessary. The bolt insulation must be undamaged.

Spare parts may only be obtained from the manufacturer.

After disassembly, the components must be inspected/evaluated for contamination and disposed of accordingly/ properly.

Analysis of hazards and risks

If the operating instructions and notes are not observed, the electrically insulating and mechanical function of the insulating flange connection is not guaranteed. No liability or warranty is accepted for damage of any kind.

ISOflanges is certified according to the Pressure Equipment Directive (PED) in Category 2, Module A2.

ISOflanges is certified according to: ISO 9001:2015, Design and sale of technical components for gas technical installations.

You can reach our sales and service department:

ISOflanges GmbH
Viehtrift 1
29308 Winsen
Germany

Telephone: +49 5143 923 49 0
E-mail: info@isoflanges.de
www.isoflanges.de