

## Example of installation of an insulating flange connection type HQ2

Without cable lugs, example 8-hole flange:

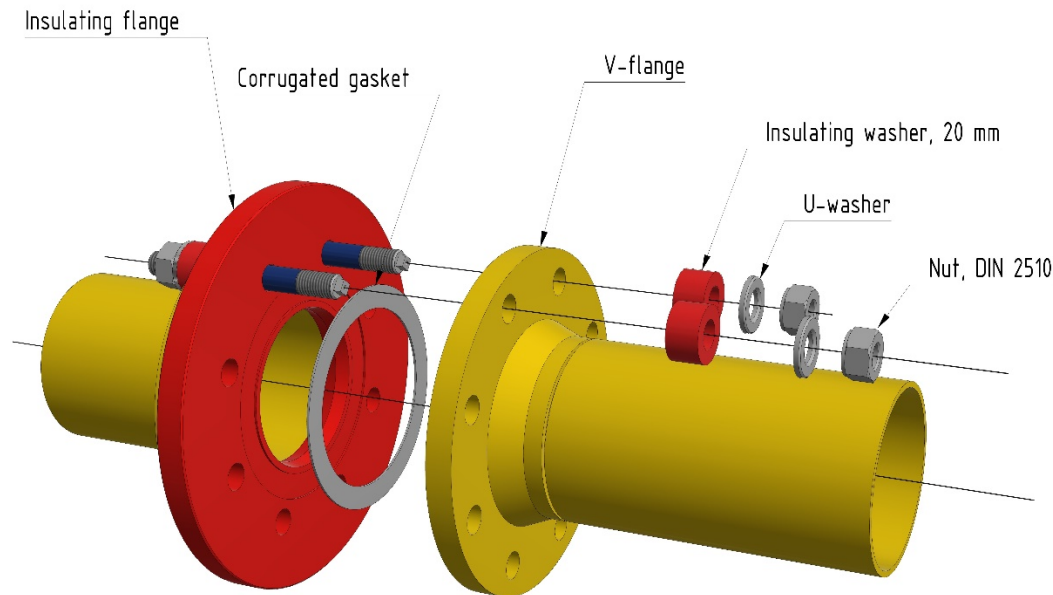

With cable lugs, example 8-hole flange:

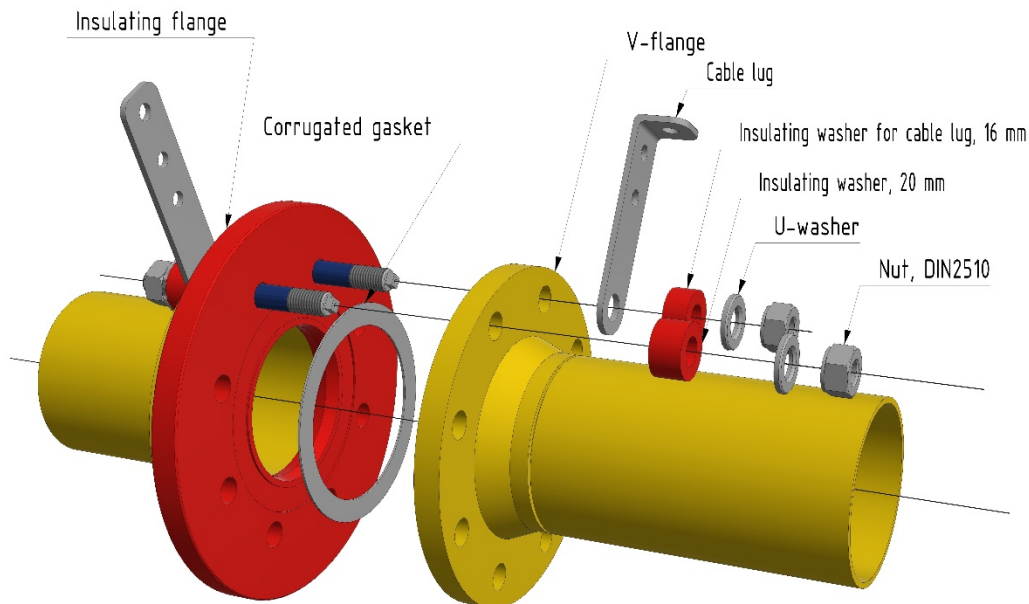

The torque to be applied is indicated in the documentation drawing of the insulating flanges.

Stud-bolt with self-lubricating coating.

Coefficient of friction of 0.12 is met for up to 5 assembly processes.

**PLEASE OBSERVE: No lubrication required!**

ISOflanges GmbH  
Viehtrift 1  
29308 Winsen

Tel: 05143 923 49 0  
Mail: [info@isoflanges.de](mailto:info@isoflanges.de)  
[www.isoflanges.de](http://www.isoflanges.de)